



DuHandling Series (DH)

THE ADVANTAGES ARE BUILT IN:
BETTER, CLEANER AND MORE EFFICIENT COOLING SYSTEMS

Superior economics

- Upfront cost is comparable to, or in many cases less expensive than, alternative air handling equipment
- Reduces system power requirements by ~40%:
 - Shifts costly latent load from chiller to free latent load at DuHandling unit
 - Lower sensible load due to relaxed temperature requirements
 - Relaxed temperature requirement (higher LWT) also increases chiller COP

Functional benefits

- More precise control of indoor environment through the ability to directly control humidity and temperature independently
- Greater comfort due to eliminating overcooling of outdoor air
- Improved indoor air quality (IAQ) through removal of airborne particulates and organisms
- Eliminates opportunities for mold formation by eliminating all points of condensation in the system

Utilization of renewable energy

- Low-quality waste heat or solar thermal energy can easily be utilized as low as 130°F to power dehumidification
- Geothermal cooling can often be used to dramatically reduce or eliminate chiller or cooling tower load

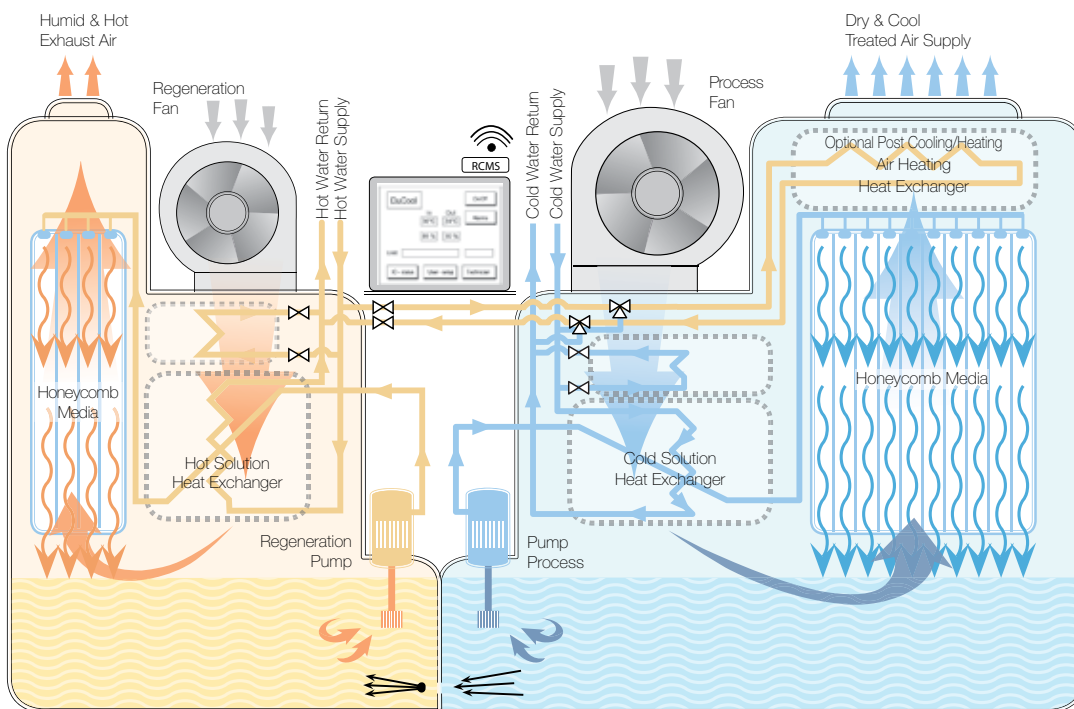

Schematic Process Diagram

Technical Specifications

DuHandling (DH) Large

Technical Specifications

General Data

Unit Model	DH – 1400		DH – 2400		DH – 3400	
Air Flow Capacities						
Supply (Treated) Air	1,400 CFM		2,400 CFM		3,400 CFM	
Regeneration Air	1,400 CFM		2,400 CFM		3,400 CFM	
Hot Water	130°F to 200°F; Maximum flow 66 gpm					
Cold Water / Glycol	50°F to 95°F; Maximum flow 66 gpm					
Minimum T between Cold & Hot Water	45°F					
Desiccant Solution LiCl (40% Concentration)	33 Gallons					
Operation Temperature Range	14°F to 122°F					
Operation Abs. Humidity Range	7 gr/lb to 210 gr/lb					
Electrical System ⁽¹⁾	460V, 3 Ph, 60Hz	208V-230V, 3 Ph, 60Hz	460V, 3 Ph, 60Hz	208V-230V, 3 Ph, 60Hz	460V, 3 Ph, 60Hz	208V-230V, 3 Ph, 60Hz
Line Current	Amp.		Amp.		Amp.	
Breaker Size	Amp.		Amp.		Amp.	
	4.4	12.7	6.9	24	10.7	27
	12	20	20	40	32	40

Thermal Mode (Renewable)

Data & Capacity (Hot & Cold Water Operation)

Tested at conditions at 86°F; 70 % R.H. ^{(2) (3)}

Hot water at 185 F, 40 gpm flow; Cold water at 42.8 F, 66 gpm flow. ⁽⁴⁾						
Sensible Cooling	47,800 Btu/h	14.0 kW	69,000 Btu/h	20.2 kW	88,712 Btu/h	26.0 kW
Latent Cooling	99,000 Btu/h	29.0 kW	139,700 Btu/h	40.9 kW	184,248 Btu/h	54.0 kW
Total Cooling	146,800 Btu/h	43.0 kW	208,700 Btu/h	61.1 kW	272,960 Btu/h	80.0 kW
	12.2 TR		17.4 TR		22.8 TR	
Moisture Extraction	10.8 Gal./h		15.3 Gal./h		21.5 Gal./h	
Temperature Reduction	32°F		27°F		25°F	
Efficiency Rating ⁽⁵⁾	25.3 COP	86 EER	26.5 COP	90 EER	22.85 COP	78 EER

Hot water at 149 F, 40 gpm flow; Cold water at 62.6 F, 66 gpm flow. ⁽⁴⁾

Sensible Cooling	15,000 Btu/h	4.4 Kw	26,300 Btu/h	7.7 kW	51,180 Btu/h	15.0 kW
Latent Cooling	55,000 Btu/h	16.1 kW	95,600 Btu/h	28.0 kW	138,868 Btu/h	40.7 kW
Total Cooling	70,000 Btu/h	20.5 kW	121,900 Btu/h	35.7 kW	190,048 Btu/h	55.7 kW
	5.8 TR		10.1 TR		15.9 TR	
Moisture Extraction	6.3 Gal./h		11 Gal./h		16 Gal./h	
Temperature Reduction	14.4°F		12.6°F		14.5°F	
Efficiency Rating ⁽⁵⁾	15.7 COP	41.2 EER	14.3 COP	53.0 EER	16.0 COP	54.6 EER

Physical Data

Weight	Lb	Lb	Lb
Net	925	937	948
Operating (including LiCl)	1,260	1,272	1,283

Dimensions	Inch
L	88
W	66
H	63

Clearances	Inch
I	40
II	20

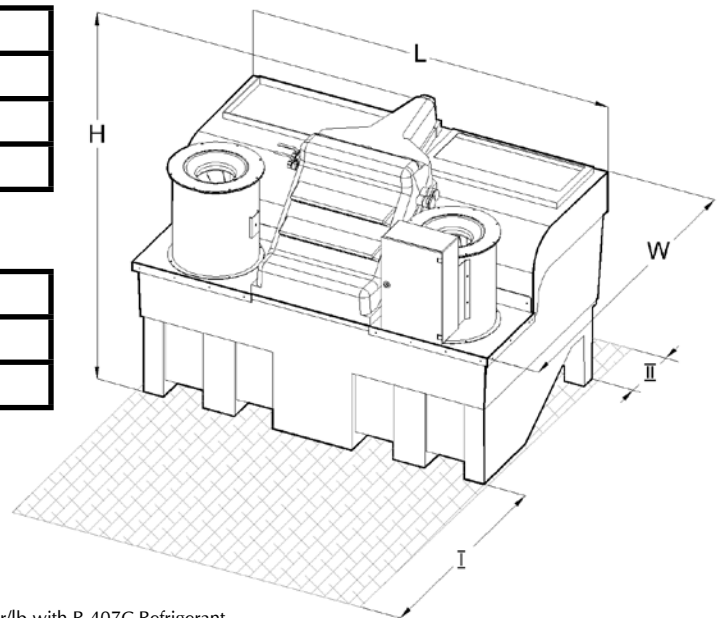

Notes:

- Units are available in different voltages with 50 Hz.
- A. The capacity ratings above are at: 86°F; 70% R.H. Absolute Humidity of 133 gr/lb with R-407C Refrigerant.
B. At 208-230V/60 Hz 3 phase, performance is 5% less than above data. At inlet temperatures below 50°F consult manufacturer for exact unit configuration.
- Deviation range for the above data (+/-) 5%.
- For a different climate and/or hot and cold water conditions please send data to manufacturer.
- COP/EER ratings are calculated without the units process fan. At hot water at 185°F, cold water at 42.8°F data includes electrical energy consumption only.
- Specifications are subject to changes without prior notice.

